



FEATURES

- Direct radiating dual 18-in design
- Optimally tuned with large very low turbulence port
- Unique woofer loading generates unbelievable impact
- Premium large coil (115 mm) components with tremendous motor strength (+20%BI)
- Powerful neodymium magnet structures reduce system weight and increase output
- Can be ground stacked or permanently suspended with sixteen 3/8 – 16 points
- Quick release rigging accessory kit available for touring applications

DESCRIPTION

Representing a significant upgrade to the legendary SB1000, EAW introduces the new SB1001 large-format dual-18-inch-loaded subwoofer. While the dimensions of the vented enclosure and the fundamental acoustical philosophy remain true to the classic, the core components have been significantly updated to include larger 115 mm voice coils, 20% higher BI and all neodymium magnet structures. The stunning result is a lighter weight reference standard that has greater impact, power handling and output capabilities than its celebrated predecessor.

Just like the SB1000 the unique driver mounting of the SB1001 maximizes cone area and allows for the integration of an extremely low turbulence port while minimizing front area, providing the acoustical performance and physical configuration well suited for creating large subwoofer arrays.

The SB1001 is perfectly suited for a wide range of applications including concert touring, arenas, large houses of worship, large auditoriums and theaters, stage and drum fill monitoring, and large dance clubs.

DUAL 18-INCH SUBWOOFER

See *NOTES TABULAR DATA* for details

CONFIGURATION

Subsystem:

<i>Transducer</i>	<i>Loading</i>
SUB 2x 18 in cone	Vented

Operating Mode:

<i>Amplifier Channels</i>	<i>External Signal Processing</i>
Single-amp LF1 / LF2	DSP w/1-way filter
Dual-amp LF1 / LF2	DSP w/1-way filter

PERFORMANCE

Operating Range: 28 Hz to 160 Hz

Nominal Beamwidth:

Horz 360°
Vert 360°

Axial Sensitivity (SPL):

LF1/LF2 (<i>whole space</i>) 95 dB	28 Hz to 160 Hz
(<i>half space</i>) 101 dB	28 Hz to 160 Hz

Input Impedance (ohms):

	<i>Nominal</i>	<i>Minimum</i>
LF1/LF2	4	3.8 @ 30 Hz
LF1/LF2	8 (each)	7.5 @ 30 Hz

High Pass Filter: High Pass=>30 Hz, 12 dB/octave Butterworth

Accelerated Life Test:

System LF1/LF2	98 V	2400 W @ 4 ohm
LF1,LF2	98 V (each)	1200 W @ 8 ohm (each)
Transducer (AES)		1200 W (each)

Calculated Axial Output Limit (*whole space SPL*):

	<i>Average</i>	<i>Peak</i>
LF/LF2 (<i>whole space</i>)	129 dB	135 dB
(<i>half space</i>)	135 dB	141 dB

ORDERING DATA

Description	Part Number
EAW SB1001 Dual 18-inch Subwoofer Black	2034316

ENCLOSURE

Material	Exterior-grade Baltic birch plywood
Finish	Wear resistant textured black paint
Grille	Powder-coated perforated steel

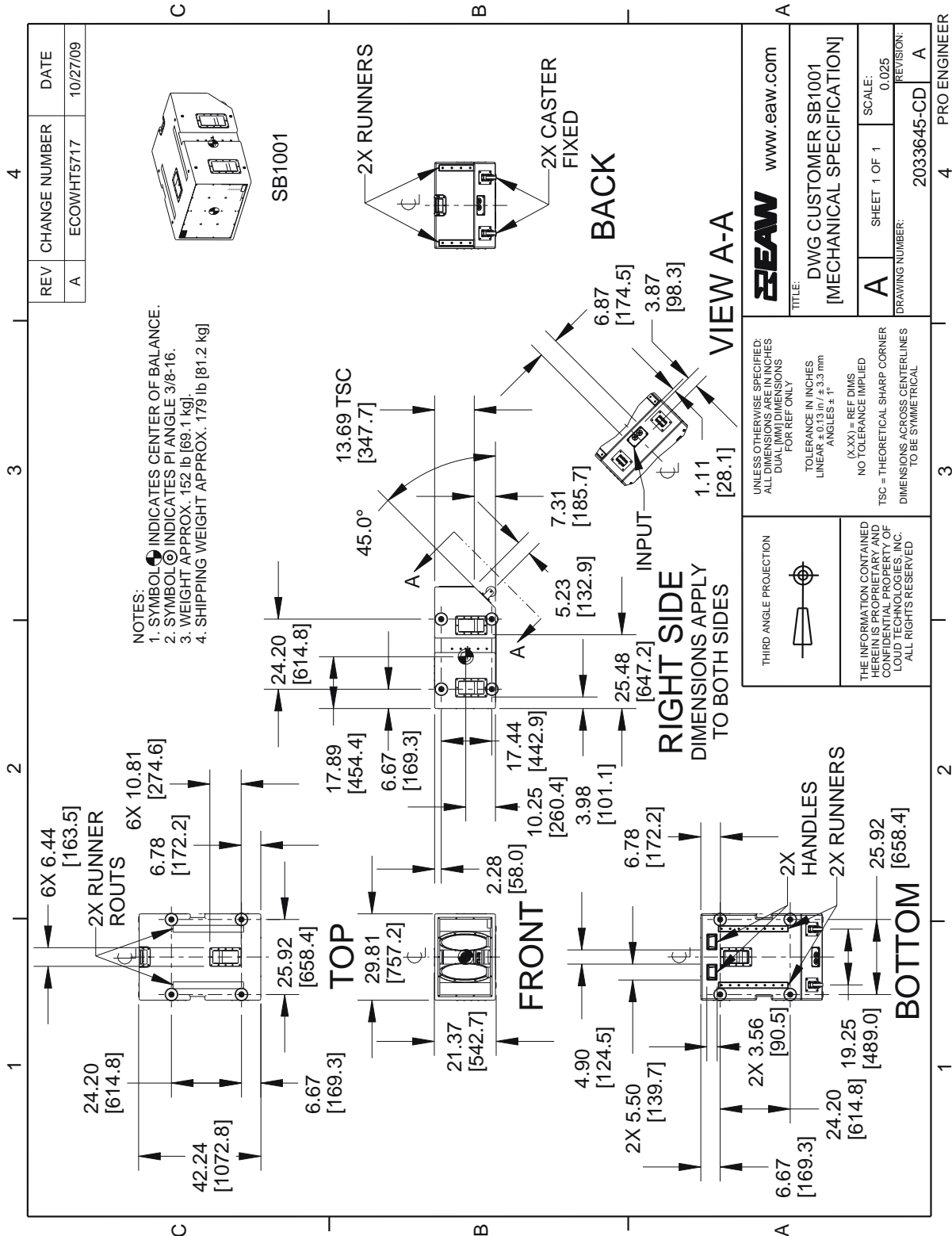

NOTE: This drawing has been reduced. Do not scale.

PERFORMANCE DATA

See *NOTES GRAPHIC DATA* for details

Frequency Response: Processed

LF 1/2 Whole Space = green

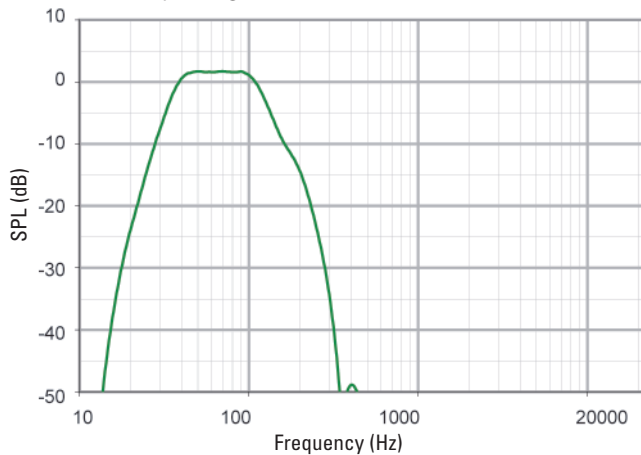

Frequency Response: Unprocessed

LF 1/2 Whole Space = green

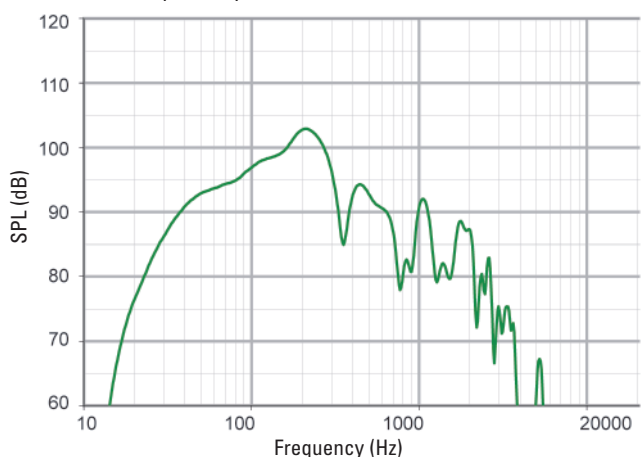

Frequency Response: Digital Signal Processor

LF = green

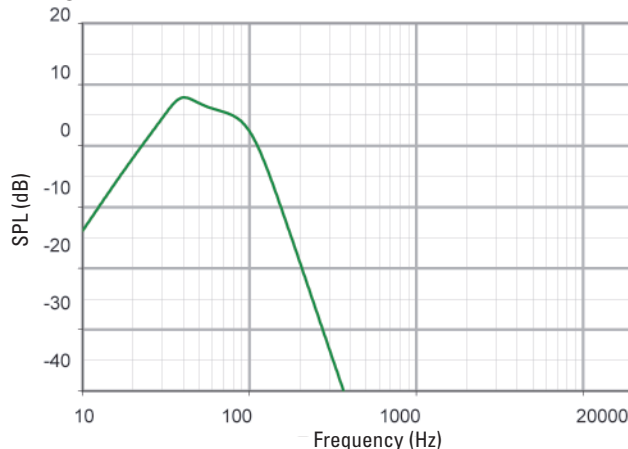

Impedance Magnitude

LF 1/2 = green, LF 1, LF 2 (each) = orange

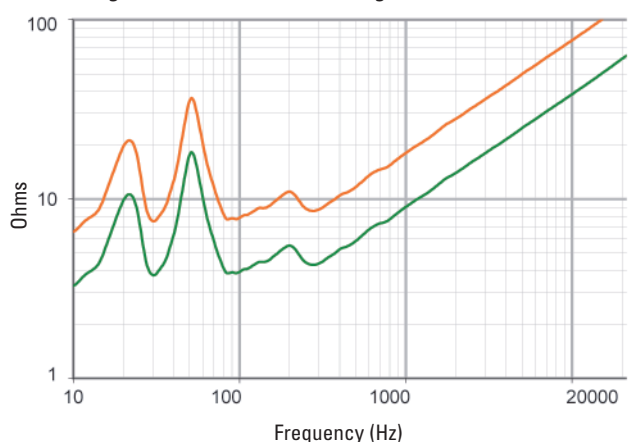

INPUT PANEL

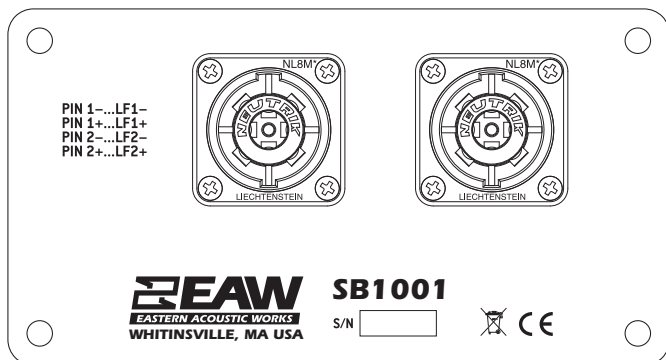

SIGNAL DIAGRAM

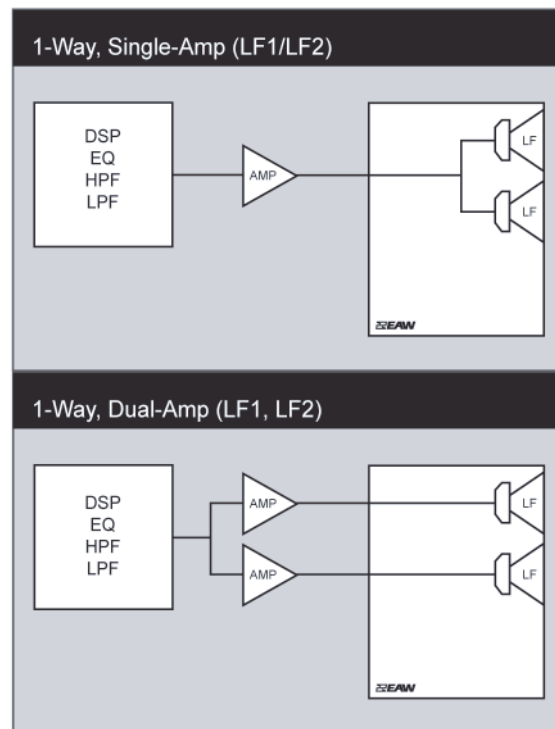

LEGEND

- DSP:** User-supplied Digital Signal Processor.
- HPF:** High Pass Filter for crossover or specified High Pass Filter.
- LPF:** Low Pass Filter for crossover.
- LF/MF/HF:** Low Frequency / Mid Frequency / High Frequency.
- AMP:** User-supplied Power Amplifier.
- XVR:** Passive LPFs, HPFs and EQ integral to the loudspeaker.

NOTES

TABULAR DATA

1. **Measurement/Data Processing Systems:** Primary - FChart: proprietary EAW software; Secondary - Brüel & Kjær 2012.
2. **Microphone Systems:** Earthworks M30; Brüel & Kjær 4133
3. **Measurements:** Dual channel FFT; length: 32 768 samples; sample rate: 48 kHz; logarithmic sine wave sweep.
4. **Measurement System Qualification** (includes all uncertainties): SPL: accuracy +/-0.2 dB @ 1 kHz, precision +/-0.5 dB 20 Hz to 20 kHz, resolution 0.05 dB; Frequency: accuracy +/-1 %, precision +/-0.1 Hz, resolution the larger of 1.5 Hz or 1/48 octave; Time: accuracy +/-10.4 µs, precision +/-0.5 µs, resolution 10.4 µs; Angular: accuracy +/-1°, precision +/-0.5°, resolution 0.5°.
5. **Environment:** Measurements time-windowed and processed to eliminate room effects, approximating an anechoic environment. Data processed as anechoic or fractional space, as noted.
6. **Measurement Distance:** 7.46 m. Acoustic responses represent complex summation of the subsystems at 20 m. SPL is referenced to other distances using the Inverse Square Law.
7. **Enclosure Orientation:** For beamwidth and polar specifications, as shown in Mechanical Specification drawing.
8. **Volts:** Measured rms value of the test signal.
9. **Watts:** Per audio industry practice, "loudspeaker watts" are calculated as voltage squared divided by rated nominal impedance. Thus, these are not True Watt units of energy as defined by International Standard.
10. **SPL:** (Sound Pressure Level) Equivalent to the average level of a signal referenced to 0 dB SPL = 20 microPascals.
11. **Subsystem:** This lists the transducer(s) and their acoustic loading for each passband. Sub = Subwoofer, LF = Low Frequency, MF = Mid Frequency, HF = High Frequency.
12. **Operating Mode:** User selectable configurations. Between system elements, a comma (,) = separate amplifier channels; a slash (/) = single amplifier channel. DSP = Digital Signal Processor.
IMPORTANT: To achieve the specified performance, the listed external signal processing must be used with EAW-provided settings.
13. **Operating Range:** Range where the processed Frequency Response stays within -10 dB SPL of the power averaged SPL within this range; measured on the geometric axis. Narrow band dips are excepted.
14. **Nominal Beamwidth:** Design angle for the -6 dB SPL points, referenced to 0 dB SPL as the highest level.
15. **Axial Sensitivity:** Power averaged SPL over the Operating Range with an input voltage that would produce 1 W at the nominal impedance; measured with no external processing on the geometric axis, referenced to 1 m.
16. **Nominal Impedance:** Selected 4, 8, or 16 ohm resistance such that the minimum impedance point is no more than 20% below this resistance over the Operating Range.
17. **Accelerated Life Test:** Maximum test input voltage applied with an EIA-426B defined spectrum; measured with recommended signal processing and Recommended Protection Filter.
18. **Calculated Axial Output Limit:** Highest average and peak SPLs possible during the Accelerated Life Test. The Peak SPL represents the 2:1 (6 dB) crest factor of the Life Test signal.
19. **High Pass Filter:** This helps protect the loudspeaker from excessive input signal levels at frequencies below the Operating Range.

GRAPHIC DATA

1. **Resolution:** To remove insignificant fine details, 1/12 octave cepstral smoothing was applied to acoustic frequency responses and 1/3 octave cepstral smoothing was applied to the beamwidth and impedance data. Other graphs are plotted using raw data.
2. **Frequency Responses:** Variation in acoustic output level with frequency for a constant input signal. Processed: normalized to 0 dB SPL. Unprocessed inputs: 2 V (4 ohm nominal impedance), 2.83 V (8 ohm nominal impedance), or 4 V (16 ohm nominal impedance) referenced to a distance of 1 m.
3. **Processor Response:** The variation in output level with frequency for a constant input signal of 0.775 V = 0 dB reference.
4. **Beamwidth:** Average angle for each 1/3 octave frequency band where, starting from the rear of the loudspeaker, the output first reaches -6 dB SPL referenced to 0 dB SPL as the highest level. This method means the output may drop below -6 dB SPL within the beamwidth angle.
5. **Impedance:** Variation in impedance magnitude, in ohms, with frequency without regard to voltage/current phase. This means the impedance values may not be used to calculate True Watts (see 9 above).
6. **Polar Data:** Horizontal and vertical polar responses for each 1/3 octave frequency band 100 Hz to 16 kHz or Operating Range.

