

HIGH END SYSTEMS

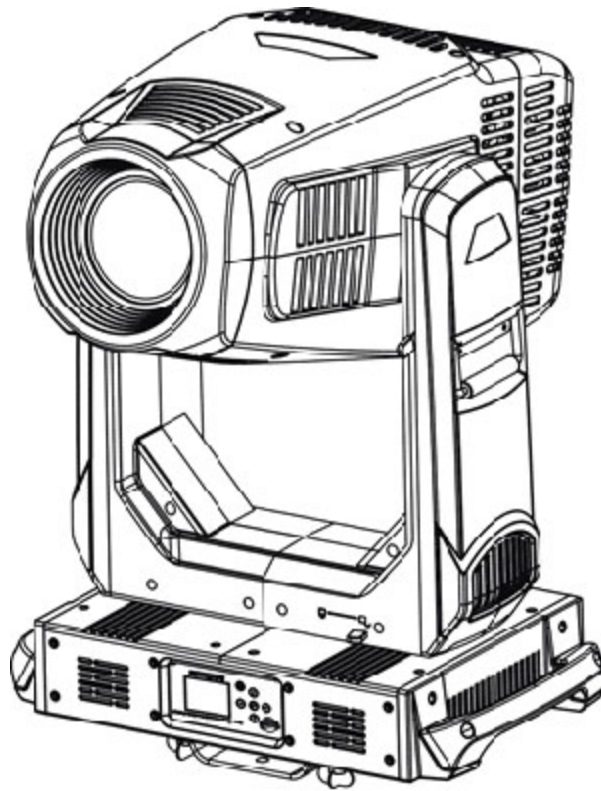

an **ETC.** Company



SolaFrame Theatre

Automated Luminaire User Manual

Version 1.2.5 — Revision C



To view a list of ETC trademarks and patents, go to [etconnect.com/ip](https://www.etconnect.com/ip). All other trademarks, both marked and not marked, are the property of their respective owners.

Information and specifications in this document are subject to change without notice.

Table of Contents

- Welcome 1
 - Contacting High End Systems 1
 - Headquarters 1
 - Technical Support 1
 - FCC Information 4
 - Patents 4
 - Terms and Conditions and Warranty Information 4
 - Product Modification Warning 4
 - Mise En Garde Contre La Modification Du Produit 4
 - Produktmodifikationswarnung 4
 - Avvertenza Sulla Modifica Del Prodotto 4
 - Advertencia De Modificación Del Producto 4
 - Important Safety Information 5

- Fixture Overview 6
 - Dimensions 7

- Safety Considerations 8
 - General Operation and Use Guidelines 9
 - Power Specifications 9

- Install the Fixture 10

- DMX Control 12
 - DMX Connector Pinout 12
 - Considerations for Ethernet (Art-Net) Connectors 12
 - Connect DMX Cables to Fixture 13
 - Terminate DMX 13

Set the DMX Start Address	14
DMX Channels	14
Configure the Fixture	15
Navigate the User Interface	15
Set Fixture Parameters	16
DMX Address	16
Info Menu	16
Set Menu	18
Test Menu	21
Preset Menu	22
Error Codes	24
Cleaning and Maintenance	26

Welcome

Congratulations on your purchase of the SolaFrame Theatre automated framing fixture. This manual provides important information for the safe installation, configuration, and maintenance of your SolaFrame Theatre fixture.

Contacting High End Systems

High End Systems, Inc. is an ETC company.

Headquarters

For Customer Service or Sales support, please contact our company headquarters:

2105 Gracy Farms Lane

Austin, TX 78758 USA

Tel: 512.836.2242

Fax: 512.837.5290

Toll-free: 800.890.8989

Website: highend.com

Technical Support

If you are having difficulties installing, configuring, or operating your SolaFrame Theatre, your most convenient resources are the references given in this manual. To search more widely, try the High End Systems, Inc. website at highend.com. Additional technical resources are available on the support website support.etcconnect.com/HES.

If you have additional questions that cannot be answered within these resources, contact High End Systems Technical Services directly at the office nearest you. Emergency support is available outside of regular business hours. Contact information is available at highend.com/about/contact-us.



Declaration of Conformity

Manufacturer's name: HAO YEANG ELECTRONIC CO., LTD
Manufacturer's address: No. 109, HaiYong Road, GuanNanYoung Industry Districe, Shiji Town
DanYu Zone, GuanZhou City, China

Distributor's name: High End Systems, Inc.
Distributor's address: 2105 Gracy Farms Lane
Austin, Texas 78758 USA

Product Name: SOLAFRAME THEATRE
Product Options: All

We hereby declare that the above referenced product complies with the essential requirements of Council Directives 2014/30/EU (EMC), 2014/35/EU (LVD) and 2011/65/EC (RoHS) .

Safety: EN 60598-1: 2015
EN 60598-2-17: 1989 A2: 1991
EN62493 (2015)
EN62471 (2008)
EN61347-2-13: 2014;
EN61347-1: 2015
EN62031: 2008+A1; 2013+A2: 2015

EMC: Emission: EN55015:20013+A1:2015,
EN61547:2009
EN 61000-3-2 (2014)
EN 61000-3-3 (2013)

High End Systems | 2105 Gracy Farms Lane | Austin TX 78758 | highend.com

ROHS:	Restricted Substances	Maximum Concentration Value (by weight in homogeneous material)
	Cadmium (Cd)	0.01%
	Lead (PB)	0.1%
	Mercury (Hg)	0.1%
	Hexavalent Chromium (Cr VI)	0.1%
	Polybrominated Biphenyl (PBB)	0.1%
	Polybrominated Diphenyl Ethers (PBDE)	0.1%

Kenneth S. Hansen



Compliance Engineer

July 10 2017

FCC Information

This equipment has been tested and found to comply with the limits for a Class A digital device, pursuant to part 15 of the FCC rules. These limits are designed to provide reasonable protection against harmful interference when the equipment is operated in a commercial environment. This equipment generates, uses, and can radiate radio frequency energy and, if not installed and used in accordance with the instruction manual, may cause harmful interference to radio communications. Operation of this equipment in a residential area is likely to cause harmful interference, in which case the user will be required to correct the interference at his own expense.

Patents

NOTICE OF INTELLECTUAL PROPERTY RIGHTS

High End Systems, Inc. products are protected by one or more patents listed on the High End Systems, Inc. website: <https://www.highend.com/patents> and/or are subject to one or more pending patents.

Terms and Conditions and Warranty Information

Complete terms and conditions and warranty information can be found on the High End Systems, Inc. website: <https://www.highend.com/pub/products/HES-Warranty-Information.pdf>.

Product Modification Warning

High End Systems products are designed and manufactured to meet the requirements of the United States and International safety regulations. Modifications to the product could affect safety and render the product non-compliant to relevant safety standards.

Mise En Garde Contre La Modification Du Produit

Les produits High End Systems sont conçus et fabriqués conformément aux exigences de règlements internationaux de sécurité. Toute modification du produit peut entraîner sa non conformité aux normes de sécurité en vigueur.

Produktmodifikationswarnung

Design und Herstellung von High End Systems entsprechen den Anforderungen der U.S. Amerikanischen und internationalen Sicherheitsvorschriften. Abänderungen dieses Produktes können dessen Sicherheit beeinträchtigen und unter Umständen gegen die diesbezüglichen Sicherheitsnormen verstoßen.

Avvertenza Sulla Modifica Del Prodotto

I prodotti di High End Systems sono stati progettati e fabbricati per soddisfare i requisiti delle normative di sicurezza statunitensi ed internazionali. Qualsiasi modifica al prodotto potrebbe pregiudicare la sicurezza e rendere il prodotto non conforme agli standard di sicurezza pertinenti.

Advertencia De Modificación Del Producto

Los productos de High End Systems están diseñados y fabricados para cumplir los requisitos de las reglamentaciones de seguridad de los Estados Unidos e internacionales. Las modificaciones al producto podrían afectar la seguridad y dejar al producto fuera de conformidad con las normas de seguridad relevantes.

Important Safety Information

Please read all instructions prior to assembling, mounting, and operating this equipment. Continued and safe operation of this fixture is the responsibility of the operator. This manual will give tips for that continued safe operation. At any time please contact High End Systems technical support for any safety concerns.

The following international note, caution, and warning symbols appear in margins throughout this manual to highlight important messages.



Note: *Notes are helpful hints and information that is supplemental to the main text.*



CAUTION: *This statement indicates that while operating, equipment surfaces may reach very high temperatures. Allow the fixture to cool before handling or servicing.*



CAUTION: *A Caution statement indicates situations where there may be undefined or unwanted consequences of an action, potential for data loss or an equipment problem.*



WARNING: *A Warning statement indicates situations where damage may occur, people may be harmed, or there are serious or dangerous consequences of an action*



WARNING: RISK OF ELECTRIC SHOCK! *This warning statement indicates situations where there is a risk of electric shock.*

Fixture Overview

For technical specifications of the SolaFrame Theatre fixture, see the technical data sheet:
[https://www.highend.com/documentation/SolaFrame Theatre/SolaFrame-Theatre-TDS.pdf](https://www.highend.com/documentation/SolaFrame%20Theatre/SolaFrame-Theatre-TDS.pdf)

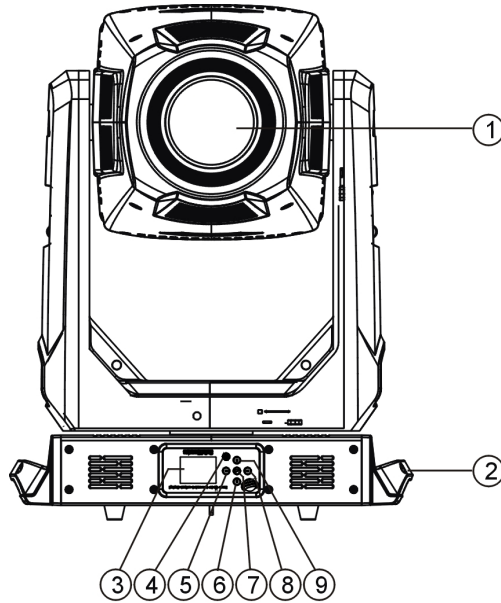

- 1: Lens
- 2: Handle
- 3: Display
- 4: [MODE/ESC] button
- 5: Left button
- 6: Down button
- 7: [Enter] button
- 8: Right button
- 9: Up button
- 10: Fuse
- 11: Power out
- 12: Power in
- 13: 5-Pin DMX in
- 14: 5-Pin DMX out
- 15: Art-Net out
- 16: Art-Net in

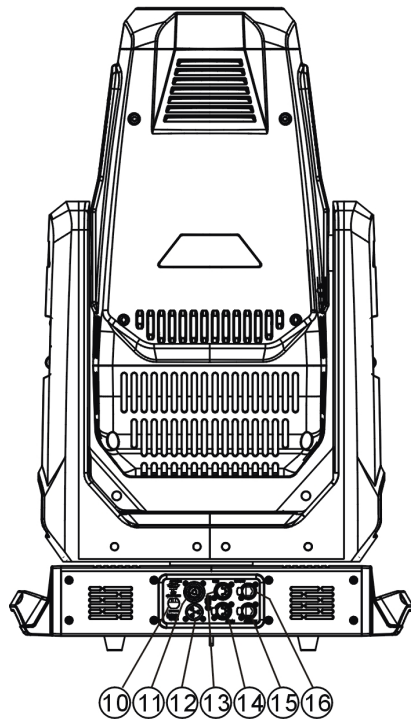

Dimensions

Dimensions shown are listed in millimeters.

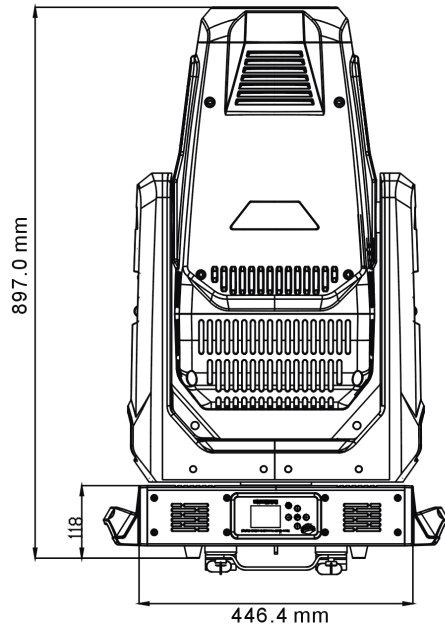
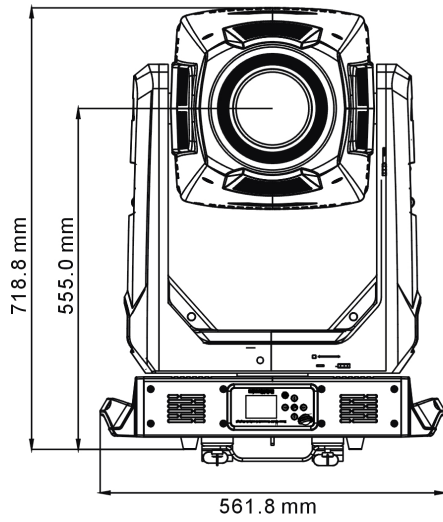
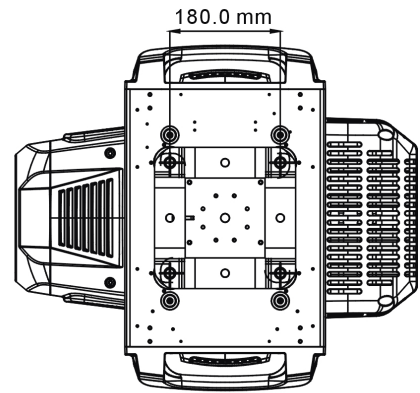
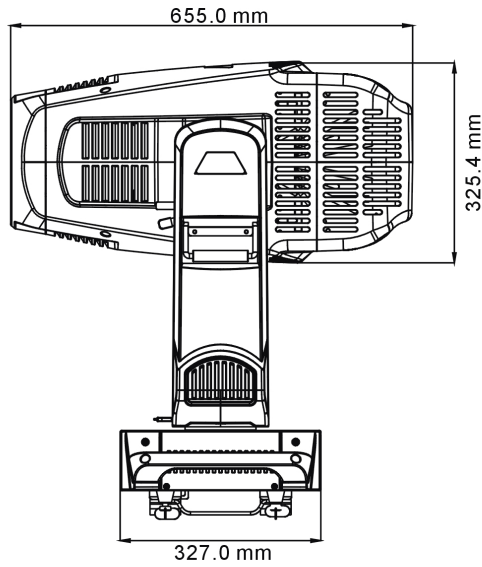

Safety Considerations

In order to ensure safe operation, follow the safety instructions and warning notes in this user manual and any instructions from the manufacturer representative.

- The SolaFrame Theatre fixture is intended for professional use only. Not for residential use. Read the entire manual before using this equipment.
 - Contact your High End Systems dealer or High End Systems technical support before performing any service in order to maintain warranty coverage.
-



WARNING: For your safety, read the following warnings and notices before use:

- This equipment is designed for operation by qualified personnel only.
 - Disconnect the unit from power and DMX and data before servicing.
 - Replace fuses with the specified type and rating only.
 - Make sure that the available voltage is within the stated range.
 - NEMA Type 1 enclosure, indoor use, dry locations only. Do not use outdoors. This fixture is intended for use where humidity does not exceed 90% (non-condensing).
 - Do not use this fixture with a damaged power lead (cord set). If the lead is damaged, it must be replaced by a qualified technician with an equivalent type before use. Contact your local authorized dealer for spare power leads.
 - Do not use this fixture if the lens, protection screen, or ultraviolet screen is damaged. Damaged lenses must be replaced before use. Contact your local authorized dealer for a replacement.
 - When the fixture has been stored or transported in cold temperatures, allow it to warm to room temperature for a minimum of one hour before applying power. Applying power to a cold fixture may cause damage to the fixture and void the manufacturer warranty.
 - This is a Class 1 device and must be grounded. Follow national and local codes.
 - Do not project the beam onto combustible substances.
 - Keep fixture head at least 0.5 m (1.64 ft) away from any flammable materials.
 - Minimum distance to lighted objects: 1.5 m (4.9 ft).
 - When you power on the fixture, you may notice smoke or odor. This is normal and should decrease gradually. If smoke or odor persists, disconnect the fixture from power and contact your High End Systems dealer or High End Systems technical support.
-



CAUTION: *Hot Surfaces. Allow the fixture to cool completely before handling and servicing.*



CAUTION: *Damages caused by the disregard of this user manual are not subject to warranty. High End Systems, Inc. and its authorized dealers will not accept liability for any resulting defects or problems.*

General Operation and Use Guidelines

- This fixture is only allowed to be operated with the maximum alternating current that is stated in the technical specifications label provided on the fixture.
- Lighting effects are not designed for permanent operation. Consistent operation breaks may ensure that the fixture will serve you for a long time without defects.
- Do not shake the fixture. Avoid brute force when installing or operating the fixture.
- When choosing the installation location, make sure that the fixture is not exposed to extreme heat, moisture, or dust.
- If using the supplied Omega brackets with quick-locking thumb screws for fixture hanging, ensure that the thumb screws have engaged a complete 90-degree positive latch.
- Operate the fixture only after having familiarized yourself with its functions. Do not permit other persons who are not qualified and familiar with its functions to operate the fixture.
- Please use the original packaging if the fixture is to be transported. ETC and High End Systems, Inc. will not be responsible for the fixture if packaging other than manufacturer provided packaging is used.
- Do not modify the fixture. Any modifications will void the warranty.
- This manual describes the proper installation and operation of this fixture. Using this fixture in any way other than the intended use may cause damage and may void the warranty.
- Misuse of this fixture or using it in a way different from the methods described in this manual may lead to personal injury and/or equipment failure.

Power Specifications

Voltage	Maximum Number of Fixtures Connected via Power In/Out	Notes
100 V–120 V	2	For more than two devices, connect the third device directly to mains power.
200 V–240 V	3	For more than three devices, connect the fourth device directly to mains power.

Install the Fixture



WARNING:

- The installation must always be secured with a secondary safety attachment. An appropriate safety cable is supplied.
 - Safety cable attachment must be rated by a safety factor of 10.
 - Use of third party clamps are permitted, but they should comply with, and be approved by, the Authority Having Jurisdiction (AHJ).
 - A supportive and stable surface must be used when the fixtures are placed on the feet.
 - The operating temperature range for this fixture is 0°C–35°C (32°F–95°F). Do not operate the fixture outside of this range.
 - Never stand directly below the installed fixture when mounting, removing, or servicing the fixture.
 - All safety and technical aspects of fixture installation must be approved by a qualified personnel before operation.
 - The installation must be regularly inspected by qualified personnel.
 - Overhead rigging must be performed by qualified personnel.
-



CAUTION: *Follow all local codes and recommended practices by the Authority Having Jurisdiction. The installation must only be carried out by qualified personnel.*

You can install the fixture in any of the orientations shown below.

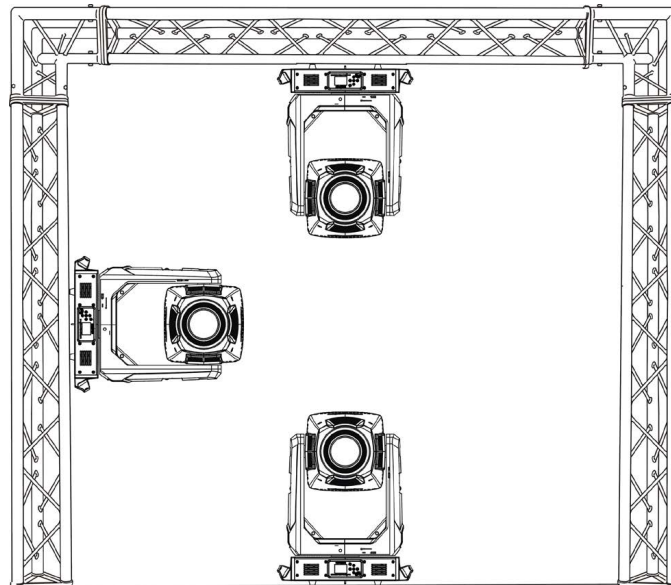

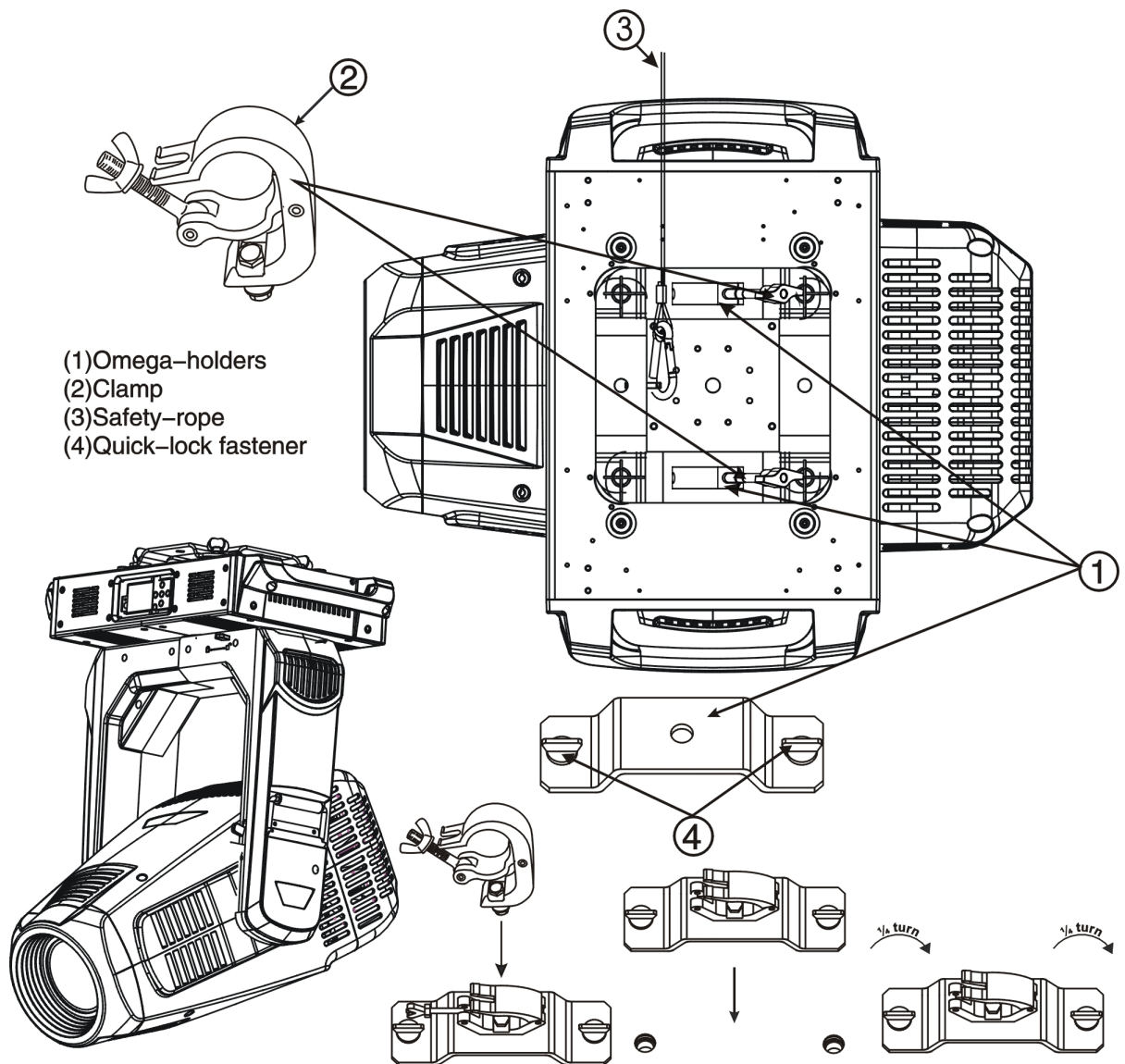

- (1)Omega-holders
- (2)Clamp
- (3)Safety-rope
- (4)Quick-lock fastener

1. Assemble the clamp (provided by others) to the Omega bracket and secure together using appropriately sized hardware (not provided).
2. Align the assembled Omega bracket and quick-lock fasteners into the respective holes on the bottom of the fixture upper enclosure.
3. Tighten each of the quick-lock fasteners fully, turning clockwise. You will hear and feel a click when the fastener is fully secured.
4. Repeat steps 1 through 3 for the second clamp and bracket.
5. Attach the provided safety cable through the attachment point on the bottom of the fixture upper enclosure and secure to the trussing system or other safe installation point. Follow local codes and recommended safety standards for securing the fixture to the installation location.
6. Attach the fixture to the installation location using the installed clamps, using the clamp manufacturer's instructions for a secure fit. When using the Omega clamp, close the safety and fully tighten the clamp wing nut until secure.
7. Inspect the installation prior to lifting the fixture overhead.

DMX Control

The SolaFrame Theatre fixture operates on standard DMX-512 control bus, controlled by a DMX console. The fixture requires 47 channels of DMX-512 in standard mode.

Two XLR termination receptacles are available: one for connection of DMX Input, and one for DMX Out (used when daisy-chaining to additional fixtures on the DMX control bus).

DMX Connector Pinout

For DMX Input, the DMX cable must have a male XLR connector on one end of the cable that connects to the fixture. When daisy-chaining DMX to the next device, prepare a DMX cable with a female XLR connector on one end and a male XLR connector on the other end. Terminate the cable ends as indicated in the pinout image below.

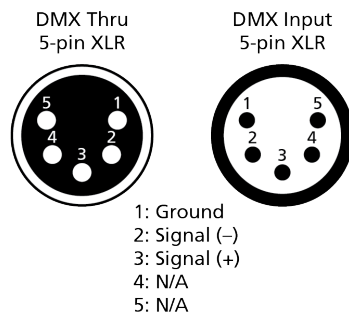

Considerations for Ethernet (Art-Net) Connectors

For fixtures connected via Ethernet (Art-Net), cable distance should not exceed 100 m, and no more than 20 fixtures should be connected in a daisy chain.

Connect DMX Cables to Fixture

The following instructions are guidelines for connecting DMX to your fixture. Your installation may vary.

1. Connect the male XLR connector of a DMX data cable to the DMX Out connector on the DMX control source.
2. Connect the female XLR connector of the DMX data cable to the DMX In connector of the first fixture on the DMX control run.
3. Continue linking the remaining fixtures by connecting a cable from the DMX Out connector of a fixture to the DMX In connector of the next fixture on the control run.



Note: A maximum of 32 DMX devices may be connected in any one DMX data run when installed in a daisy-chain fashion.

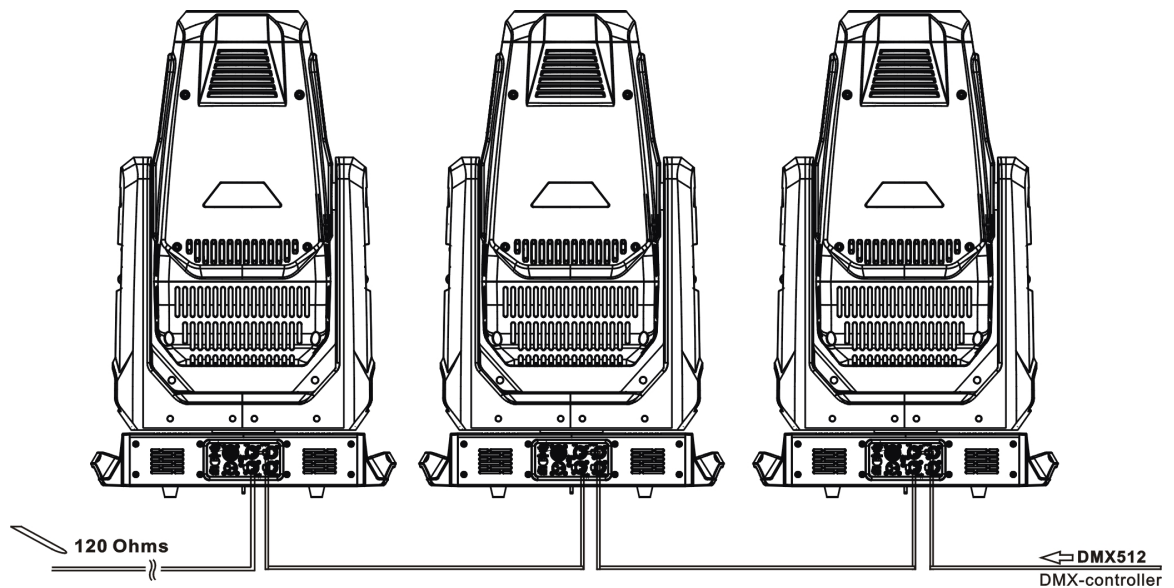

Terminate DMX

Use a DMX terminator or install a resistor on the last fixture of the DMX control run to prevent corruption (data reflection) of the digital control signal by electrical noise.

A DMX terminator is an XLR plug with a 120 Ω resistor connected between pins 2 and 3 that can be installed into the DMX output receptacle of the last fixture in the DMX control run. This plug is available and sold separately. Contact your local High End dealer for ordering information (visit highend.com/about/contact-us to locate a High End dealer).

Set the DMX Start Address

Give each fixture a unique DMX starting address so that the correct fixture responds to the control signals. This DMX start address is the channel number from which the fixture starts to “listen” to the digital control information sent out from the control source.

Modify the fixture DMX start address on the user interface, located on the upper enclosure. See [DMX Address on page 16](#).



Example: The SolaFrame Theatre has 47 channels. If you set the DMX starting address of the first fixture to 1, you could set the second fixture to 48 ($47+1$), the third to 95 ($48+47$), and so on.

DMX Channels

The most current DMX Map data for the SolaFrame Theatre can be found on the High End Systems, Inc. website:



[https://www.highend.com/documentation/SolaFrame Theatre/SolaFrameTheatre-protocol.pdf](https://www.highend.com/documentation/SolaFrame%20Theatre/SolaFrameTheatre-protocol.pdf)

Configure the Fixture

You can configure SolaFrame Theatre fixtures through the onboard user interface.

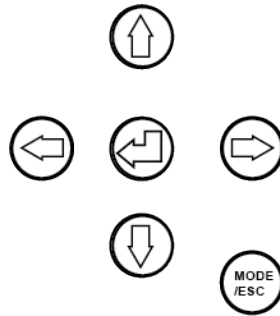
Navigate the User Interface



1. Press and hold the [MODE/ESC] button until the display flashes. (The display is powered by battery when the fixture has no power.)
2. Browse the menu by pressing the up, down, left, or right navigation buttons.
3. Press the Enter button  to select a menu item.
4. Modify the selection by pressing the up, down, left, or right navigation buttons according to the selection.
5. Press the Enter button  to confirm a modified selection.
6. To exit the menu, press the [MODE/ESC] button.



Note: *If you press the Enter button to confirm a selection and push no other buttons, the user interface returns to the default display after 10 seconds.*

Set Fixture Parameters

This section provides instructions to configure and set up the SolaFrame Theatre. See [Navigate the User Interface on the previous page](#) for information about the navigation buttons.

Provide power to the fixture before configuring it. If you do not provide power, the fixture will use battery power to power the user interface.

DMX Address

Navigate: Main Menu → Address

Set the DMX address for the fixture. The default value is 001.

Info Menu

Set the Time Information

Navigate: Main Menu → Info → Time Info

Parameter	Value	Description
Current Time	XXXX (Hours)	Running time of the fixture from the last time that the fixture was powered on, shown in hours (h). The counter resets after the fixture is turned off.
Ttl Life Hrs	XXXX (Hours)	Total running time of the device, shown in hours (h).
Last Run Hrs	XXXX (Hours)	Running time of the fixture from the last time that the run time value was reset, shown in hours (h).
LED Hours	XXXX (Hours)	Total running time of the fixture LEDs, shown in hours (h).
Timer PIN	Timer PIN XXX	You must enter the Timer PIN in order to access the Clr Last Run menu item. The default Timer PIN is 038.
Clr Last Run	<ul style="list-style-type: none">• ON• OFF	This password-protected menu item resets the Last Run Hrs value. You must enter the Timer PIN to access this menu item. Select ON to clear the value for the Last Run Hrs parameter for the fixture.
LED Time PIN	LED Time PIN XXX	You must enter the LED Time PIN in order to access the Clear LED Time menu item. The default LED Time PIN is 038.
Clear LED Time	<ul style="list-style-type: none">• ON• OFF	This password-protected menu item resets the LED Hours value. You must enter the LED Time PIN to access this menu item. Select ON to clear the value for the LED Hours parameter.

View Fixture Errors

Navigate: Main Menu → Info → Error Info

Displays any current fixture errors. See [Error Codes on page 24](#) for information about the errors.

View DMX Values for Channels

Navigate: Main Menu → Info → Value Disp.

View the DMX value of each of the fixture's channels (parameters of the fixture). Scroll to the parameter that you want to view (Pan, Tilt, etc.) and view the value. The DMX value that you view is the DMX value that displays on the main window of the UI until you select a different DMX value to view.

View Fixture Head Temperature

Navigate: Main Menu → Info → Head Temp

Displays the current fixture temperature as read from the fixture head (near the CMY filter).

View Ethernet IP Address

Navigate: Main Menu → Info → Ethernet IP

Displays the Ethernet IP address for the fixture. You can modify this value in the Set menu. See [Access Service Settings on page 20](#).

View Software Version

Navigate: Main Menu → Info → Software Ver

Displays the software version for the fixture.

Set Menu

Set the Status Options

Navigate: Main Menu → Set → Status

Parameter	Value	Description
No DMX Mode	<ul style="list-style-type: none">• Close• Hold• Auto• Music	Control mode when DMX is absent. The default value is Hold.
Pan Reverse	<ul style="list-style-type: none">• ON• OFF	Reverse the pan movement of the fixture. The default value is OFF.
Tilt Reverse	<ul style="list-style-type: none">• ON• OFF	Reverse the tilt movement of the fixture. The default value is OFF.
Pan Degree	<ul style="list-style-type: none">• 630• 540	Change the pan rotation of the fixture from the default setting of 540 degrees to 630 degrees.
Encoders	<ul style="list-style-type: none">• ON• OFF	Turn on or off the encoder feedback for pan and tilt movement. You may want to turn off encoders when working on a fixture so that you can move pan and tilt without the fixture automatically moving back to position.
Pan/Tilt Spd	1–4	Set the speed (scan mode) of pan and tilt movement. The default value is 1. Use this parameter to make fine adjustments to pan and tilt movement in order to correct for mis-stepping when the fixture is installed on its side (side-hung, or "Outrig").
Hibernation	<ul style="list-style-type: none">• OFF• 1–99 minutes	Hibernation mode forces the LEDs and stepper motors to power off when the fixture loses DMX control signal for a set period of time. The default time setting is 15 minutes.
Defogger	<ul style="list-style-type: none">• Defog OnOP• Defog OnPwr• Defog Off	Set when the Defogger (heater for the front lens) is turned on: <ul style="list-style-type: none">• Defog OnOP: Turn on Defogger when LEDs are above 0% intensity• Defog OnPwr: Turn on Defogger when the fixture is powered (default value)• Defog Off: Turn off Defogger
Dimming Mode	<ul style="list-style-type: none">• Standard• Theatrical	Set the dimming curve. The default value is Standard.
CMY Curve	<ul style="list-style-type: none">• Linear• Non-Linear	Set the CMY curve. The default value is Linear.

Select Input

Navigate: Main Menu → Set → Select Input

Select the control input for the fixture:

- DMX Only
- Art-Net on IP2
- Art-Net on IP10
- sACN

Set Universe for Art-Net and sACN

Navigate: Main Menu → Set → Set Universe

When using Art-Net control input, set a universe value of 000–255.

When using sACN control input, set a universe value of 001–255.

Access Service Settings

Navigate: Main Menu → Set → Service PIN

Parameter	Value	Description
Service PIN	Service PIN XXX	You must enter the Service PIN in order to access the other Service Setting parameters. The default Service PIN is 050.
RDM UID	Manufacturer ID and fixture serial number	<p>This password-protected menu item lets you modify the RDM UID. You must enter the Service PIN to access this menu item.</p> <p>Note: Remote Device Management (RDM) requires that all RDM devices have a unique identifier (UID) that consists of the manufacturer ID and serial number. Modifying this setting can break the RDM capability of this fixture.</p> <p>Duplicate RDM UIDs on the same DMX control run will result in a data collision, causing a communication failure. Ensure that all fixtures have a unique RDM UID if RDM functionality is to be used.</p> <p>If DMX splitters are used and RDM control is to be used, these splitters must support RDM.</p>
Ethernet IP	XXX.XXX.XXX.XXX	<p>This password-protected menu item lets you modify the IP address. You must enter the Service PIN to access this menu item.</p> <p>The default IP address is 002.142.058.034.</p>
Ethernet Mask IP	XXX.XXX.XXX.XXX	<p>This password-protected menu item lets you modify the IP subnet mask. You must enter the Service PIN to access this menu item.</p> <p>The default IP subnet mask is 255.000.000.000.</p>
Clr Err Info	<ul style="list-style-type: none"> • ON • OFF 	<p>This password-protected menu item lets you clear error messages after you have fixed the errors. You must enter the Service PIN to access this menu item.</p> <p>Set this parameter to ON in order to clear the error messages. The default setting is OFF.</p>

Set Display Settings

Navigate: Main Menu → Set → Disp. Setting

Parameter	Value	Description
Shutoff Time	02–60 minutes	Enter the amount of time the fixture waits after the last user interface button press until the display goes to sleep. The default value is 5 minutes.
Flip Display	<ul style="list-style-type: none">• ON• OFF	Flip the display 180° when the fixture is mounted vertically. The default value is OFF. Shortcut: With the main UI window displayed, press [>] to flip the display 180°. Press [<] to flip it back to its original orientation.
Key Lock	<ul style="list-style-type: none">• ON• OFF	Lock the user interface. The default value is OFF. To unlock the user interface buttons, press and hold the [MODE/ESC] button for three seconds.

Set the Temperature Scale

Navigate: Main Menu → Set → Temp. C/F

Select the temperature scale for the fixture:

- Celsius (default value)
- Fahrenheit

Reset Fixture to Factory Default Settings

Navigate: Main Menu → Set → Reset Default

Select ON to reset the fixture to the factory default settings.

Test Menu

Reset (Home) the Mechanical Positions on the Fixture

Navigate: Main Menu → Test → Home

Reset ("home") all features on the fixture, including, pan, tilt, colors, gobos, etc.

Test an Individual Channel

Navigate: Main Menu → Test → Test Channel

Run a self-test program on individual channels. The default value is Control. Select a different channel to run a self-test on that channel.

Manually Set an Individual Channel

Navigate: Main Menu → Test → Manual Ctrl.

Select an individual channel on the fixture and manually set the channel value. While in Manual Control mode, all effects are canceled, the shutter opens, and the dimmer intensity is set to 100%.

Re-Calibrate an Individual Feature

Navigate: Main Menu → Test → Calibration

Please contact technical support at High End Systems, Inc. before using this parameter. See [Contacting High End Systems on page 1](#).

You must enter the Calibration PIN in order to access the Calibration menu items. The default Calibration PIN is 050.

Once you have accessed the Calibration menu, select an individual feature on the fixture and manually calibrate it to a new "home" setting.

Preset Menu

Set the Playback Settings

Navigate: Main Menu → Preset → Play Back

Playback settings allow you to run an Auto Program as a Master fixture or in stand-alone mode, or to receive playback information from a different Master fixture.

Preset programming requires one fixture to act as the Master. All other SolaFrame Theatre fixtures that are connected to the designated Master fixture can then receive Auto Programs from the Master fixture.



Example: You edit groups of scenes into Programs 1–10 on the Master fixture.

- Program 2 is assigned to Part 1
- Program 4 is assigned to Part 2
- Program 6 is assigned to Part 3

- * Fixtures assigned as Slave 1 will play back Part 1
- * Fixtures assigned as Slave 2 will play back Part 2
- * Fixtures assigned as Slave 3 will play back Part 3

Select the appropriate playback setting:

- **DMX Control:** Return the fixture to DMX control from another playback mode.
- **Set To Slave:** Fixture will play back the Auto Program that is defined on the Master fixture.
- **Auto Program:** Fixture runs an Auto Program either in stand-alone mode or as a Master fixture. Use the Select Prog parameter to select the program (see [Select an Auto Program below](#)).

Select an Auto Program

Navigate: Main Menu → Preset → Select Prog.

Select the Auto Program that the fixture will run either in stand-alone mode or as a Master fixture.

Program	Range	Default Value
Prog. Part 1	Program 1–Program 10	Program 1
Prog. Part 2	Program 1–Program 10	Program 2
Prog. Part 3	Program 1–Program 10	Program 3

Edit an Auto Program

Navigate: Main Menu → Preset → Edit Program

Create the Auto Program that the fixture will run either in stand-alone mode or as a Master fixture (see [Select an Auto Program on the previous page](#)).

Navigate to the Auto Program that you want to edit (Program 1, Program 2, etc.), and then set the scene (SC001, SC002, etc.) for each step (Step 01, Step 02, etc.) in the Auto Program. You can set a maximum of 64 steps. The SolaFrame Theatre fixture provides 250 pre-programmed scenes, or you can customize scenes using the Edit Scenes parameter (see [Edit a Scene or Capture \(Record\) a Scene below](#)).

Edit a Scene or Capture (Record) a Scene

Navigate: Main Menu → Preset → Edit Scenes

The SolaFrame Theatre fixture provides 250 pre-programmed scenes that you can use or edit to build an Auto Program. Each scene is a snapshot of a set of fixture parameters (for example, color, beam quality and pattern, intensity, focus, etc.) that you can assign to a step in an Auto Program. Select the scene (Scene 001, Scene 002, etc.) that you want to edit, and then set the parameters for the scene or capture the parameters for the scene from the current DMX input.

In addition to standard SolaFrame Theatre features (pan, tilt, etc.), scene parameters include the following options.

Parameter	Value	Description
Fade Time	0–255 seconds	Enter the crossfade time applied to parameters when the scene plays.
Scene Time	0.2–99.9 seconds	Enter how long the scene will play before the next scene plays. The default value is 0.3 seconds.
Input By Out		Capture the parameter values for the scene from the current DMX input.

Capture (Record) Multiple Scenes

Navigate: Main Menu → Preset → Scenes Input

You can capture DMX data and record those parameters as a series of scenes. Select the start and end scene numbers for the range of scenes that you want to record. The fixture records the incoming DMX data into the selected scenes, with each change in DMX data triggering the next scene in the range. When all scenes in the range have been recorded, the display returns to the main menu.



Note: *While capturing the DMX data, the SolaFrame Theatre fixture does not play back the DMX input; it only captures the data. You must edit or play back the scene after recording is complete to verify the results. We suggest that you prepare the scenes on a DMX controller with a zero crossfade for all parameters between steps. Remember that any change of a DMX value will automatically advance to the next scene during capture.*

Error Codes

When you apply power to the fixture, it runs a calibration (homing) sequence and displays any errors that it detects.



Example: When the display shows “Err Info: Pan Movement”, it means there is an error in channel 1. When multiple errors are present they will cycle on the display twice, and then the fixture will reset (restart). Any errors that remain after two reset cycles are not correctable by reset alone and will require service. Please contact support if detailed assistance is needed.

Animation

This message displays after the reset of the fixture if any of the following conditions exist:

- the magnetic-indexing circuit malfunctions (optical or magnetic sensor failure)
- the stepper motor is defective or the related IC driver on the main PCB has failed
- the Animation movement is not located in the default position after the reset

Blade Rot

This message displays after the reset of the fixture if any of the following conditions exist:

- the magnetic-indexing circuit malfunctions (optical or magnetic sensor failure)
- the stepper motor is defective or the related IC driver on the main PCB has failed
- the Blade rotation is not located in the default position after the reset

Color

This message displays after the reset of the fixture if any of the following conditions exist:

- the fixture head's magnetic-indexing circuit malfunctions (optical or magnetic sensor failure)
- the stepper motor is defective or the related IC driver on the main PCB has failed
- the Color wheel is not located in the default position after the reset

Focus

This message displays after the reset of the fixture if any of the following conditions exist:

- the magnetic-indexing circuit malfunctions (optical or magnetic sensor failure)
- the stepper motor is defective or the related IC driver on the main PCB has failed
- the Focus wheel is not located in the default position after the reset

Gobo 1

This message displays after the reset of the fixture if any of the following conditions exist:

- the magnetic-indexing circuit malfunctions (optical or magnetic sensor failure)
- the stepper motor is defective or the related IC driver on the main PCB has failed
- Gobo Wheel 1 is not located in the default position after the reset

Gobo 2

This message displays after the reset of the fixture if any of the following conditions exist:

- the magnetic-indexing circuit malfunctions (optical or magnetic sensor failure)
- the stepper motor is defective or the related IC driver on the main PCB has failed
- Gobo Wheel 2 is not located in the default position after the reset

Gobo Rot 1

This message displays after the reset of the fixture if any of the following conditions exist:

- the magnetic-indexing circuit malfunctions (optical or magnetic sensor failure)
- the stepper motor is defective or the related IC driver on the main PCB has failed
- Gobo Rotating Wheel 1 is not located in the default position after the reset

Pan movement

This message displays after the reset of the fixture if any of the following conditions exist:

- the yoke's magnetic-indexing circuit malfunctions (optical or magnetic sensor failure)
- the stepper motor is defective or the related IC driver on the main PCB has failed
- the Pan movement is not located in the default position after the reset

Tilt movement

This message displays after the reset of the fixture if any of the following conditions exist:

- the fixture head magnetic-indexing circuit malfunctions (optical or magnetic sensor failure)
- the stepper motor is defective or the related IC driver on the main PCB has failed
- the Tilt movement is not located in the default position after the reset

Zoom

This message displays after the reset of the fixture if any of the following conditions exist:

- the magnetic-indexing circuit malfunctions (optical or magnetic sensor failure)
- the stepper motor is defective or the related IC driver on the main PCB has failed
- the Zoom wheel is not located in the default position after the reset

Cleaning and Maintenance



CAUTION: *Disconnect the fixture from mains power before starting any maintenance procedures.*

Keep the following in mind during regular service and inspection:

- All screws for installing the fixture or parts of the fixture must be tightly connected and must not be corroded.
- There must not be any deformations to the housing, lenses, rigging, and installation points (ceiling, suspension, trussing).
- Moving parts must not show any signs of wear and must move smoothly without issue.
- The power supply cables must not show any damage, material fatigue, or sediment.
- If spare parts are required, order only genuine parts from your local authorized dealer.

To ensure that the fixture remains in good working condition and does not fail prematurely, regular maintenance is recommended.

1. Clean the inside and outside lens regularly using a damp, lint-free cloth to avoid loss of output due to accumulation of dust/dirt on the lens. Never use alcohol or solvents.
2. Clean the fans regularly to ensure maximum airflow and efficient cooling. This will ensure that the light source operates in the best possible condition.

HIGH END SYSTEMS



an **ETC** Company

Headquarters ■ 2105 Gracy Farms Lane, Austin, TX, 78758 USA ■ Tel +512 836 2242 ■ Fax +512 837 5290
Global Offices ■ London, UK ■ Holzkirchen, DE ■ Hong Kong

Web highend.com ■ **Support** support.etcconnect.com/HES

© 2020 Electronic Theatre Controls, Inc. ■ Product information and specifications subject to change.

ETC intends this document to be provided in its entirety. ■ Trademark and patent info: etcconnect.com/ip

SolaFrame Theatre User Manual Rev C Released 2020-02