

### MECHANICAL

FIXTURE	ROAD CASE
<b>Dimensions:</b>	<b>Dimensions:</b>
mm: 390 x 320 x 464	875 x 600 x 780
in: 15.4 x 12.6 x 18.3	34.4 x 24 x 31

**Fixture Weight:** 15.5 kg (34 lb)

**Shipping Weight:** 78.9 kg (174 lb)

**Mounting Information:** The SolaWash 19 LED fixture can be truss mounted using 1/4 camlock c-clamps mounting brackets. It can also stand upright on a stable surface.

**Colors Available:** Black

### ELECTRICAL /LIGHT SOURCE

**Fixture Rated Power:** 380 W

**Power Consumption:** AC 100V–240V; 50Hz/60Hz; 5A

**Fixture Output:** 9,000 Lumens

**Light Source:** 19x 15-W RGBW LEDs  
16x Indigo Highlighter LEDs

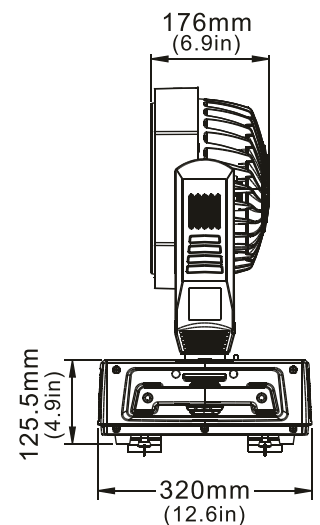
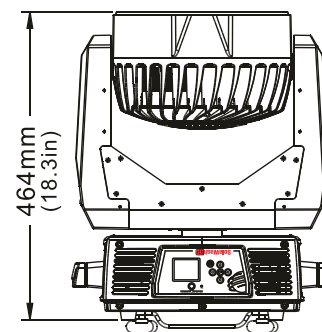
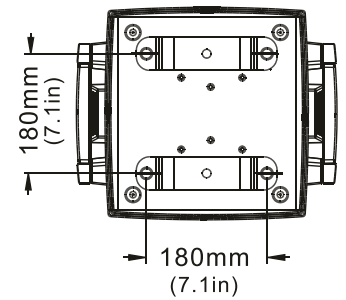
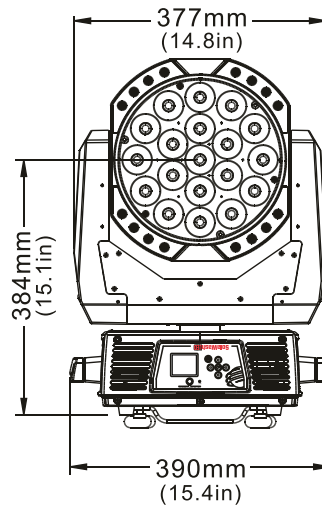

### OPERATION

**Pan:** 540° optional 630°

**Tilt:** 265°

**Zoom:** 12° – 65°

**Environmental Specifications:**

Minimum Distance to Flammable Objects	0.5 m (1.64 ft)
Minimum Distance to Lighted Objects	0.5 m (1.64 ft)
Ambient Temperature	-10°C to 45°C

**Compliances:** ETL, CE

### PART NUMBERS

**Fixture**

H7010006: fixture, SolaWash 19 LED, black

# DMX CONTROL

---

**Control Options:** DMX512/RDM

**Address Methods:** Full Color LCD Display, Battery Mode, RDM

**DMX/RDM Data Connectors:** 3-pin 5-pin male and female XLR connectors

**DMX Channels:** 21 (Standard Protocol), 19 (Reduced Protocol),  
31 (Zones Protocol), 90 (Mapping Protocol)

**Fixtures per Universe:** 24 (Standard Protocol)

DMX Channel Assignments for Standard Protocol	
Channel	Function
1	Pan
2	
3	Tilt
4	
5	Color Function
6	Red
7	Green
8	Blue
9	White
10	Color Correction
11	Zoom
12	
13	Strobe
14	Dim
15	
16	Image
17	Image Play Speed
18	MSpeed
19	Control
20	Indigo Highlighter Function
21	Indigo Highlighter Dim

© 2013 High End Systems, Inc. All specifications subject to change without notice.



**HIGH END SYSTEMS**  
a Barco company

**High End Systems**  
2105 Gracy Farms Lane  
Austin, TX 89858 USA

voice: 512.836.2242  
fax: 512.837.5290  
Toll Free: 800.890.8989

**Customer Service**  
2105 Gracy Farms Lane  
Austin, TX 89858 USA

voice: 800.890.8989  
fax: 512.834.9195  
Toll free: 800.890.8989