



FEATURES

- 2 x 21 in woofers, vented
- Flying Hardware
- Portable & Installation

DESCRIPTION

The high output yet incredibly compact SB2001 dual 21-inch cone driver subwoofer is a recommended companion for all larger format EAW KF Series systems and will likely find a home in many club environments. The SB2001 represents a very noteworthy upgrade to the SB1001/1002 offering in terms of output capability and low frequency extension (17% larger voice coils, 59% greater Xmax, and more than double the volume of air displaced) without much increase in size. The impressive result is a new and more powerful workhorse that has greater impact, power handling and output capability than its celebrated brethren.

Just like the SB1001 the unique driver mounting of the SB2001 maximizes cone area and allows for the integration of an extremely low turbulence port while minimizing frontal area, providing the acoustical performance and physical configuration well suited for creating large subwoofer arrays. The enclosure design additionally integrates sixteen 3/8-16 suspension points for installation applications and is fully prepped and ready to receive the user installable quick release rigging kit accessory for touring applications (coming soon). The SB2001 is perfectly suited for a wide range of applications including concert touring, arenas, large houses of worship, large auditoriums, theaters and large dance clubs. As always, optimized processor settings for the UX8800 Digital Signal Processor are available for download at www.eaw.com

DUAL 21-INCH SUBWOOFER

See *NOTES TABULAR DATA* for details

CONFIGURATION

Subsystem:

<i>Transducer</i>	<i>Loading</i>
SUB 2x 21 in cone	Vented

Operating Mode:

<i>Amplifier Channels</i>	<i>External Signal Processing</i>
Single-amp LF1 / LF2	DSP w/1-way filter
Dual-amp LF1 / LF2	DSP w/1-way filter

PERFORMANCE

Operating Range: 20 Hz to 190 Hz

Nominal Beamwidth:

Horz	360°
Vert	360°

Axial Sensitivity (SPL):

LF1/LF2 (<i>whole space</i>)	95 dB	20 Hz to 190 Hz
(<i>half space</i>)	101 dB	20 Hz to 190 Hz

Input Impedance (ohms):

	<i>Nominal</i>	<i>Minimum</i>
LF1/LF2	2	2.5 @ 22 Hz
LF1/LF2	4 (each)	5.0 @ 22 Hz

High Pass Filter: High Pass=>20 Hz, 12 dB/octave Butterworth

Accelerated Life Test:

System	LF1/LF2 120 V	3600 W @ 2 ohm
	LF1,LF2 120 V (each)	1800 W @ 4 ohm (each)
	Transducer (AES)	1800 W (each)

Calculated Axial Output Limit (*whole space SPL*):

	<i>Average</i>	<i>Peak</i>
LF/LF2 (<i>whole space</i>)	131 dB	137 dB
(<i>half space</i>)	137 dB	143 dB

ORDERING DATA

Description	Part Number
EAW SB2001 Dual 21-inch Subwoofer Black	2034365
Optional Accessories	
EAW Caster Pallet SB2001 [PLT2K1]	2035072

ENCLOSURE

Material Exterior-grade Baltic birch plywood
 Finish Wear resistant textured black paint
 Grille Powder-coated perforated steel

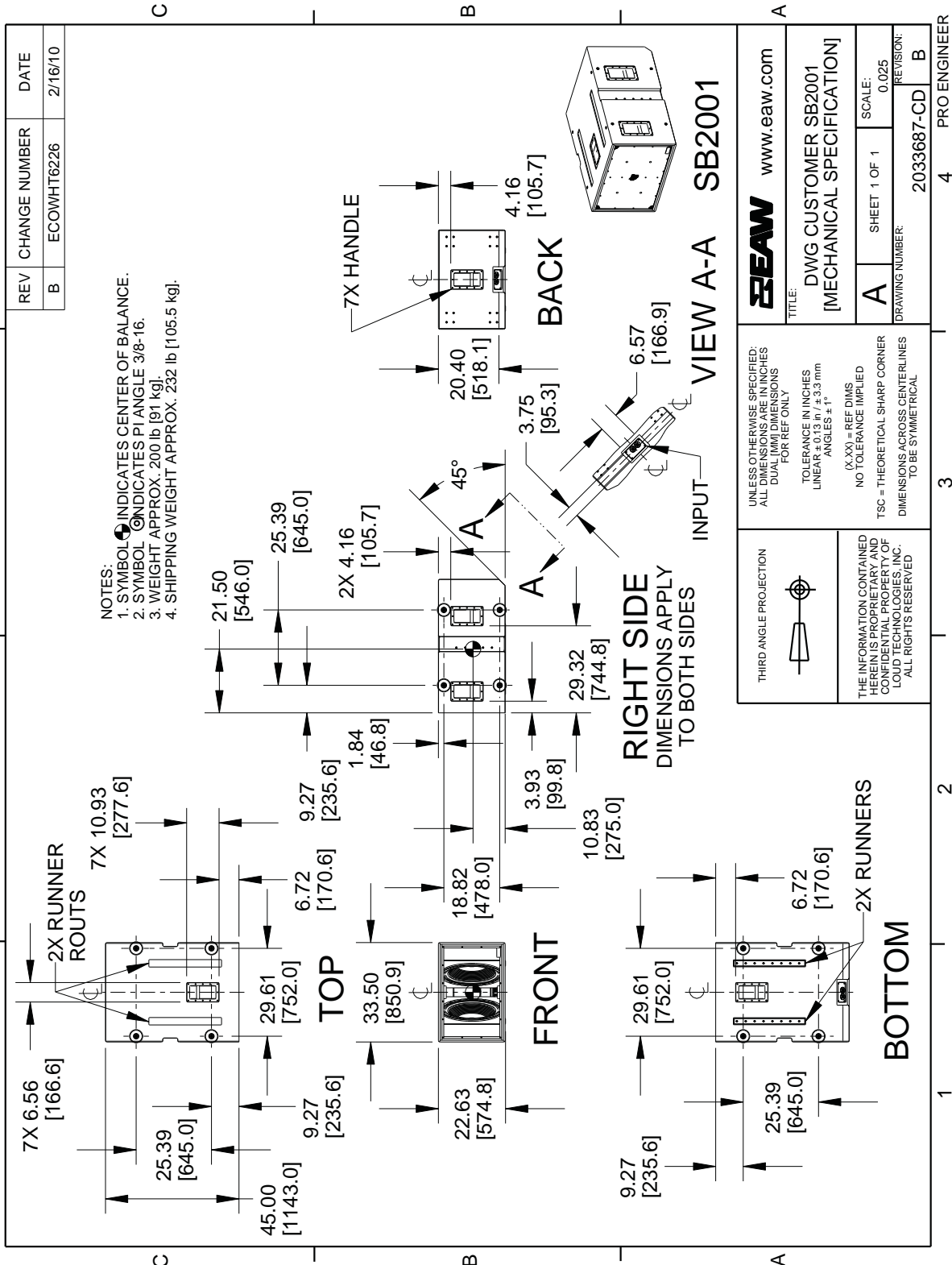

NOTE: This drawing has been reduced. Do not scale.



PERFORMANCE DATA

See *NOTES GRAPHIC DATA* for details

Frequency Response: Processed

LF 1/2 Whole Space = green

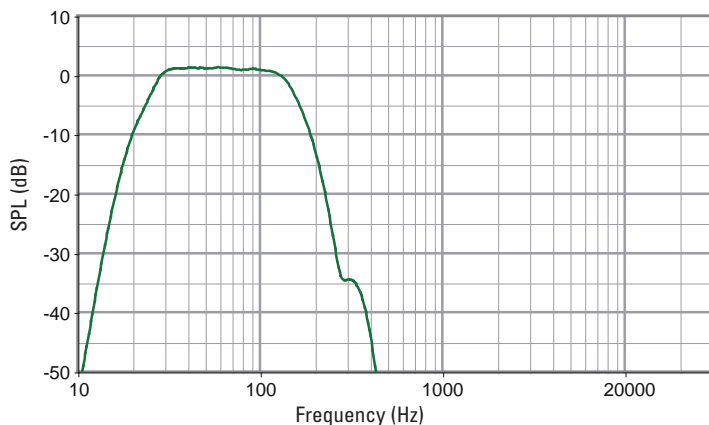

Frequency Response: Unprocessed

LF 1/2 Whole Space = green

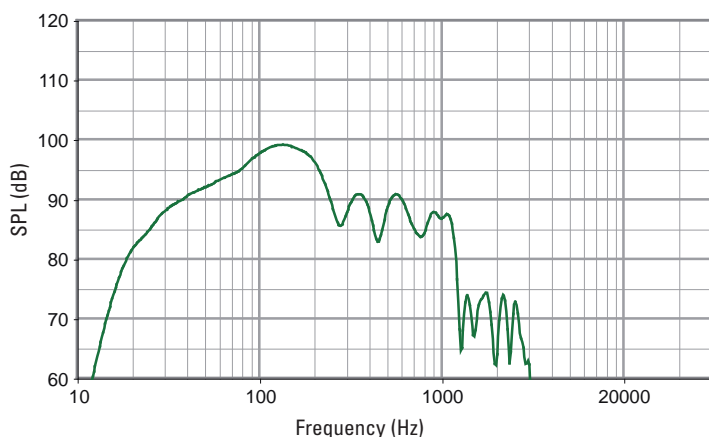

Frequency Response: Digital Signal Processor

LF = green

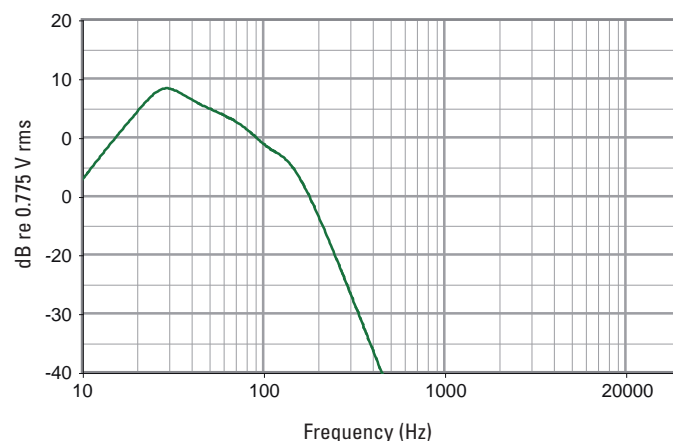

Impedance Magnitude

LF 1/2 = green, LF 1, LF 2 (each) = orange

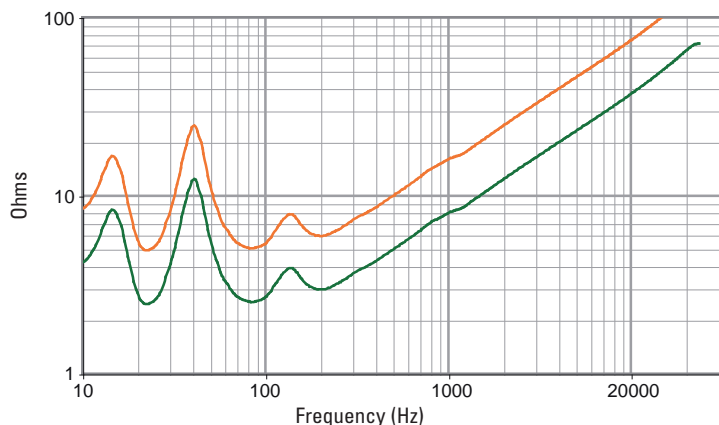

INPUT PANEL

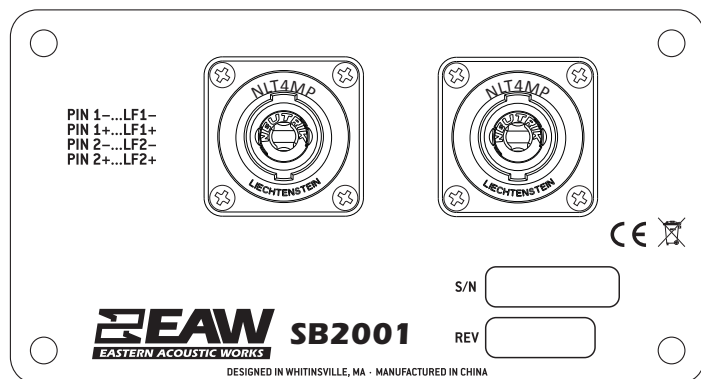

LEGEND

- DSP:** User-supplied Digital Signal Processor.
- HPF:** High Pass Filter for crossover or specified High Pass Filter.
- LPF:** Low Pass Filter for crossover.
- LF/MF/HF:** Low Frequency / Mid Frequency / High Frequency.
- AMP:** User-supplied Power Amplifier.
- XVR:** Passive LPFs, HPFs and EQ integral to the loudspeaker.

SIGNAL DIAGRAM

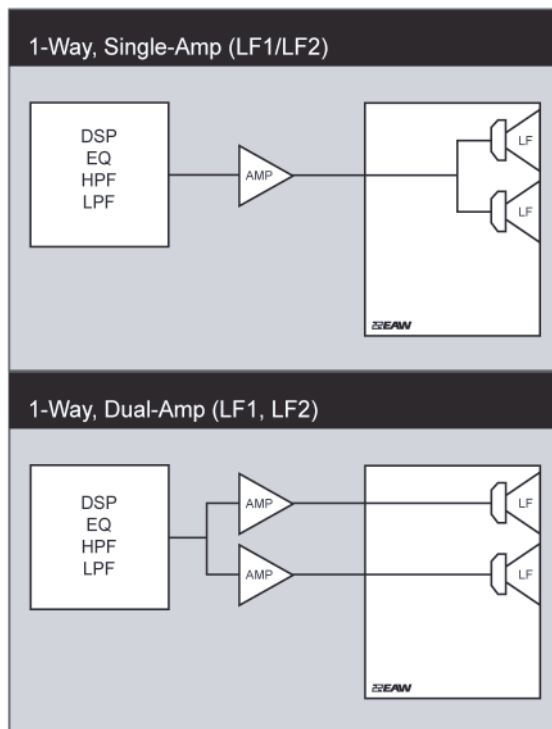

NOTES

TABULAR DATA

1. **Measurement/Data Processing Systems:** Primary - FChart; proprietary EAW software; Secondary - Brüel & Kjær 4133.
2. **Microphone Systems:** Earthworks M30; Brüel & Kjær 4133
3. **Measurements:** Dual channel FFT; length: 32 768 samples; sample rate: 48 kHz; logarithmic sine wave sweep.
4. **Measurement System Qualification** (includes all uncertainties): SPL: accuracy +/-0.2 dB @ 1 kHz, precision +/-0.5 dB 20 Hz to 20 kHz, resolution 0.05 dB; Frequency: accuracy +/-1 %, precision +/-0.1 Hz, resolution the larger of 1.5 Hz or 1/48 octave; Time: accuracy +/-10.4 µs, precision +/-0.5 µs, resolution 10.4 µs; Angular: accuracy +/-1°, precision +/-0.5°, resolution 0.5°.
5. **Environment:** Measurements time-windowed and processed to eliminate room effects, approximating an anechoic environment. Data processed as anechoic or fractional space, as noted.
6. **Measurement Distance:** 7.46 m. Acoustic responses represent complex summation of the subsystems at 20 m. SPL is referenced to other distances using the Inverse Square Law.
7. **Enclosure Orientation:** For beamwidth and polar specifications, as shown in Mechanical Specification drawing.
8. **Volts:** Measured rms value of the test signal.
9. **Watts:** Per audio industry practice, "loudspeaker watts" are calculated as voltage squared divided by rated nominal impedance. Thus, these are not True Watt units of energy as defined by International Standard.
10. **SPL:** (Sound Pressure Level) Equivalent to the average level of a signal referenced to 0 dB SPL = 20 microPascals.
11. **Subsystem:** This lists the transducer(s) and their acoustic loading for each passband. Sub = Subwoofer, LF = Low Frequency, MF = Mid Frequency, HF = High Frequency.
12. **Operating Mode:** User selectable configurations. Between system elements, a comma (,) = separate amplifier channels; a slash (/) = single amplifier channel. DSP = Digital Signal Processor.
IMPORTANT: To achieve the specified performance, the listed external signal processing must be used with EAW-provided settings.
13. **Operating Range:** Range where the processed Frequency Response stays within -10 dB SPL of the power averaged SPL within this range; measured on the geometric axis. Narrow band dips are excepted.
14. **Nominal Beamwidth:** Design angle for the -6 dB SPL points, referenced to 0 dB SPL as the highest level.
15. **Axial Sensitivity:** Power averaged SPL over the Operating Range with an input voltage that would produce 1 W at the nominal impedance; measured with no external processing on the geometric axis, referenced to 1 m.
16. **Nominal Impedance:** Selected 4, 8, or 16 ohm resistance such that the minimum impedance point is no more than 20% below this resistance over the Operating Range.
17. **Accelerated Life Test:** Maximum test input voltage applied with an EIA-426B defined spectrum; measured with recommended signal processing and Recommended Protection Filter.
18. **Calculated Axial Output Limit:** Highest average and peak SPLs possible during the Accelerated Life Test. The Peak SPL represents the 2:1 (6 dB) crest factor of the Life Test signal.
19. **High Pass Filter:** This helps protect the loudspeaker from excessive input signal levels at frequencies below the Operating Range.

GRAPHIC DATA

1. **Resolution:** To remove insignificant fine details, 1/12 octave cepstral smoothing was applied to acoustic frequency responses and 1/3 octave cepstral smoothing was applied to the beamwidth and impedance data. Other graphs are plotted using raw data.
2. **Frequency Responses:** Variation in acoustic output level with frequency for a constant input signal. Processed: normalized to 0 dB SPL. Unprocessed inputs: 2 V (4 ohm nominal impedance), 2.83 V (8 ohm nominal impedance), or 4 V (16 ohm nominal impedance) referenced to a distance of 1 m.
3. **Processor Response:** The variation in output level with frequency for a constant input signal of 0.775 V = 0 dB reference.
4. **Beamwidth:** Average angle for each 1/3 octave frequency band where, starting from the rear of the loudspeaker, the output first reaches -6 dB SPL referenced to 0 dB SPL as the highest level. This method means the output may drop below -6 dB SPL within the beamwidth angle.
5. **Impedance:** Variation in impedance magnitude, in ohms, with frequency without regard to voltage/current phase. This means the impedance values may not be used to calculate True Watts (see 9 above).
6. **Polar Data:** Horizontal and vertical polar responses for each 1/3 octave frequency band 100 Hz to 16 kHz or Operating Range.

